

**INDUSTRIAL  
COMBUSTION**

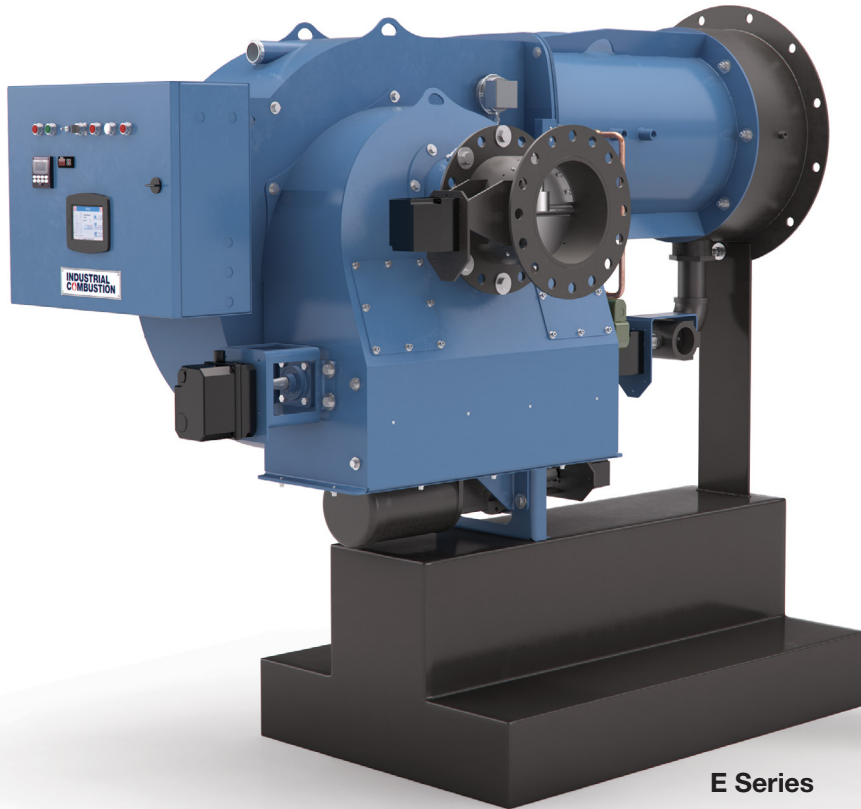

E Series

# **BURNER SOLUTIONS**

**Quick Product Reference Guide**

# The Industrial Combustion burner difference.

Industrial Combustion is a leading manufacturer of burners designed for commercial, industrial, and institutional applications. The history of our product line is a long and enviable one. For nearly 70 years, our burners have been part of virtually every major boiler manufacturer's packaged products.

Superior design is the key to our products' ongoing popularity. Industrial Combustion was the first company to introduce air-atomizing systems to burner designs. Since then, we have led the industry in the development of new burner technologies. Our commitment to research and development assures that customers receive the most technologically advanced burner systems available.

Today, our wide range of products has enabled the company to become a leader in both domestic and international markets. In addition to use as standard equipment for most leading boiler manufacturers, Industrial Combustion products are the burner of choice when upgrading existing boiler installations for maximum fuel efficiency.

Our burners are developed to deliver an impressive return on investment and feature the following characteristics:

- **Maximum efficiency:** True forced draft design controls the air and fuel mixture, resulting in complete combustion.
- **Low maintenance:** Modern, reliable controls maintain adjustment for dependable performance.
- **Save energy:** Retrofit your boilers with our high-efficiency, state-of-the-art burners.

**Industries Served:**

- Healthcare
- Chemical
- Food & Beverage
- Education
- Commercial
- Government & Military
- Manufacturing
- Oil Sands
- Petroleum & Refineries
- Pharmaceutical & Bio-Tech
- Pulp & Paper
- Utilities

Capacity	Light Commercial		Commercial/Institutional		Light Industrial		Industrial		Heavy Industrial		Power/Utility		Petrochemical/Oil Sands	
	MMBTU (Input)	BHP (BHP = 42,000 BTU/hr)												
			0.4	3	8	15	50	125	500	1,225	500	12,500	30,000	
			10	75	200	375	1,200	3,000	12,500	30,000				
	<b>Commercial Burners</b>													
	<b>Industrial Burners</b>													
	<b>Special Application Burners</b>													

# Products Overview

Industrial Combustion offers a choice of burner capacities ranging from 375,000 to 100,000,000 BTU per hour. These units provide superior performance in boiler, heater, furnace, kiln, and dryer applications and are designed to perform to maximum efficiency with either gas or oil. Combination units enable operators to use the most economical fuel without costly equipment changeover or adjustments.

Special application burners exceeding standard inputs can be engineered by our industrial burner division.



## XL/LNXL – Firetube & Watertube Series

- Designed for large firetube and watertube applications
- **Fuels:** Gas, #2 Oil, or Combination
- **Gas Input (MBTU/hr):** 37,800 to 92,400
- **Oil Input (US GPH):** 270 to 660
- **Thermal Output (BHP):** 900 to 2,200
- **Shipping Weight (lbs):** 12,000 approx.

Emissions	Turndown	Model Range	Boiler HP	Furnace Pressure	Minimum Gas Pressure	Mode of Operation	Fuel	Parallel Positioning
Uncontrolled	Up to 10:1	378 - 924	900 - 2,200	6	10	Full Modulation	Gas, Oil, Comb.	Required
<30 PPM	Up to 8:1	378 - 924	900 - 2,200	6	10	Full Modulation	Gas & Comb.	Required

Note: A parallel-positioning system is required for burner management and combustion control. Consult factory for options.

## S1/LNS1 – Series

- Designed for a wide range of applications such as firetube and firebox boilers, heaters, furnaces, kilns and dryers
- **Fuels:** Gas, #2-6 Oil, or Combination
- **Gas Input (MBTU/hr):** 46,200 to 63,000
- **Oil Input (US GPH):** 330 to 450
- **Thermal Output (BHP):** 1,100 to 1,500
- **Shipping Weight (lbs):** 7,000 to 8,750

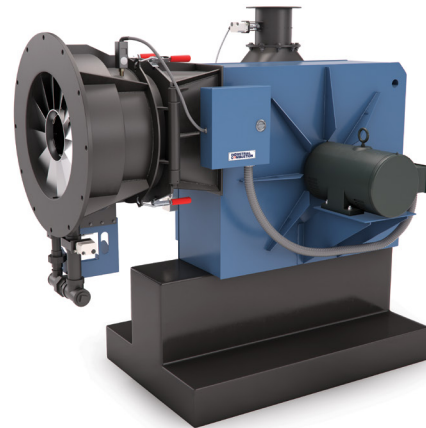

Emissions	Turndown	Model Range	Boiler HP	Furnace Pressure	Minimum Gas Pressure	Mode of Operation	Fuel	Parallel Positioning
Uncontrolled	Up to 6:1	462 - 630	1,100 - 1,500	8	9	Full Modulation	Gas, Oil, Comb.	Optional
<30 PPM	Up to 6:1	462 - 630	1,100 - 1,500	8	9	Full Modulation	Gas, Oil, Comb.	Optional

## SBR-30 – Series

- Designed for a variety of boiler types such as firetubes and watertubes
- **Fuels:** Gas, #2 Oil
- **Gas Input (MBTU/hr):** 16,800 to 54,600
- **Oil Input (US GPH):** 120 to 390
- **Thermal Output (BHP):** 400 to 1,300
- **Shipping Weight (lbs):** 400 HP burners: 2,300 to 3,000 approx. Larger sizes: TBD



Emissions	Turndown	Model Range	Boiler HP	Furnace Pressure	Minimum Gas Pressure	Mode of Operation	Fuel	Parallel Positioning
<30 PPM	Up to 10:1	168 - 546	400 - 1,300	3.6 to 5.6	5	Full Modulation	Gas, Oil	Optional

## E/LNE – Series

- Designed for firetube, firebox, heaters, kilns, dryers and watertube applications
- **Fuels:** Gas, #2 Oil, or Combination
- **Gas Input (MBTU/hr):** 8,400 to 42,000
- **Oil Input (US GPH):** 60 to 300
- **Thermal Output (BHP):** 200 to 1,000
- **Shipping Weight (lbs):** 3,150

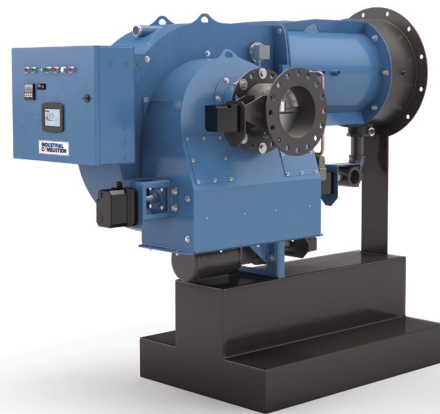

Emissions	Turndown	Model Range	Boiler HP	Furnace Pressure	Minimum Gas Pressure	Mode of Operation	Fuel	Parallel Positioning
Uncontrolled	Up to 10:1	84 - 420	200 - 1,000	4 - 9	2.1	Full Modulation	Gas, Oil, Comb.	Optional
<30 PPM	Up to 10:1	84 - 420	200 - 1,000	4 - 9	2.1	Full Modulation	Gas & Comb.	Optional

## D/LND – Series

- Designed for a wide range of applications such as firetube and firebox boilers, heaters, furnaces, kilns and dryers
- **Fuels:** Gas, #2-6 Oil, or Combination
- **Gas Input (MBTU/hr):** 3,360 to 42,000
- **Oil Input (US GPH):** 24 to 300
- **Thermal Output (BHP):** 80 to 1,000
- **Shipping Weight (lbs):** 1,000 to 5,500



Emissions	Turndown	Model Range	Boiler HP	Furnace Pressure	Minimum Gas Pressure	Mode of Operation	Fuel	Parallel Positioning
Uncontrolled	Up to 6:1	42 - 420	100 - 1,000	1.5 - 4	2	Full Modulation	Gas, Oil, Comb.	Optional
<30 PPM	Up to 6:1	34 - 420	80 - 1,000	5.2	2	Full Modulation	Gas & Comb.	Optional
<9 PPM	Up to 6:1	126 - 336	300 - 800	4.1 - 7.7	6	Full Modulation	Gas, Oil, Comb.	Standard

## MTH – Series

- Designed for process heating applications such as thermal fluid system and hot oil heating, firetube, watertube, firebox, driers and ovens
- **Fuels:** Gas
- **Gas Input (MBTU/hr):** 2,500 to 63,000
- **Thermal Output (BHP):** 60 to 1,500
- **Shipping Weight (lbs):** 700 to 12,000 approx.

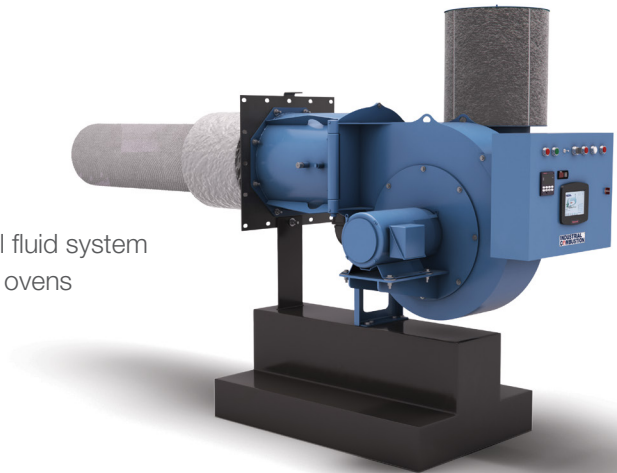

Emissions	Turndown	Model Range	Boiler HP	Furnace Pressure	Minimum Gas Pressure	Mode of Operation	Fuel	Parallel Positioning
<9 PPM	Up to 5:1	25 - 630	60 - 1,500	2 - 12	1	Full Modulation	Gas	Optional

## V – Series

- Designed for firetube, watertube, cast iron, firebox, ovens, kilns and heater applications
- Fuels: Gas, #2 Oil, or Combination
- Gas Input (MBTU/hr): 1,300 to 16,800
- Oil Input (US GPH): 9.3 to 120
- Thermal Output (BHP): 31 to 400
- Shipping Weight (lbs): 450 to 1,450

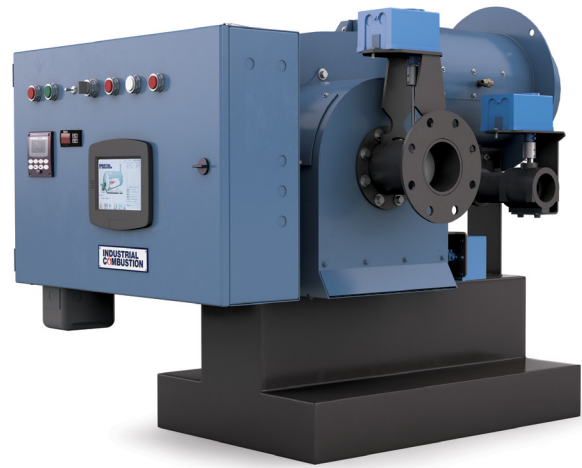

Emissions	Turndown	Model Range	Boiler HP	Furnace Pressure	Minimum Gas Pressure	Mode of Operation	Fuel
Uncontrolled	Up to 8:1	13 - 168	31 - 400	0.4 - 4.3	8.1	Full Modulation	Gas, Oil, Comb.
<30 PPM	Up to 5:1	13 - 147	31 - 350	0.5 - 4.8	8.1	Full Modulation	Gas, Oil, Comb.

## Q – Series

- Designed for cast iron sectional boilers, firebox, commercial watertube, firetube, furnace and oven applications
- Fuels: Gas
- Gas Input (MBTU/hr): 375 to 2,500
- Thermal Output (BHP): 9 to 60
- Shipping Weight (lbs): 350 to 550



Emissions	Model Range	Boiler HP	Furnace Pressure	Minimum Gas Pressure	Mode of Operation	Fuel	Parallel Positioning
Uncontrolled	37 - 250	9 - 60	0.75 - 1	4	On/Off	Gas	Optional



# Controls Help Make the Difference.

Industrial Combustion burners can truly reach their full potential when paired with an appropriate, integrated burner management system. Only through proper controls can the burner constantly fire at peak performance. There are numerous options from several manufacturers that can add significant fuel savings and increased efficiency.

- Parallel Positioning
- Controlling Lead/Lag
- Variable-Speed Drive
- Adjusting Oxygen Trim



Touchscreen Controls

Industrial Combustion's advanced burner control systems include a complete burner cabinet featuring feedwater pump controls, water level controls, and a single-point power supply.

Request a Control Systems Comparison from your local representative.

## Burner and Control Upgrades Are Easier Than Ever.

Industrial Combustion's engineering team can design a turnkey solution for any boiler and any application. Contact an Industrial Combustion authorized distributor to help determine beneficial upgrades to your system.

### Evaluate your burner and controls for an upgrade if:

- Existing burners are cycling on/off frequently wasting energy
- Your burner or boiler controls are more than 10 years old
- Burner controls are not fully integrated with boiler loads
- You must reduce emissions while maintaining efficiency
- Alternate fuels could provide energy savings and/or reduced emissions



351 21st Street, Monroe, WI 53566 USA  
608.325.3141 • info@ind-comb.com  
ind-comb.com